

UNITED LAGUNA WOODS MUTUAL

SECTION 36 RAMPS

PROPOSED JANUARY 2008

APRIL 2008, RESOLUTION 01-08-62

GENERAL REQUIREMENTS REVISED JUNE 2011, RESOLUTION 01-11-104

GENERAL REQUIREMENTS REVISED JANUARY 2016, RESOLUTION 01-16-08

1.0 GENERAL REQUIREMENTS

- 1.1 **PERMITS AND FEES:** A Mutual Consent for Manor Alterations is required for all alterations to the building. A City of Laguna Woods permit may be required. All fees for both Mutual and City permits shall be paid for by the Member and/or his contractor. Member and/or his contractor must supply the Manor Alterations Department with City permit numbers prior to beginning work.
- 1.2 **MEMBERS RESPONSIBILITY:** The Member is solely responsible for the maintenance and repair of all alterations to the building. Removal may be required upon sale of a manor, or deterioration of the alteration. Further, Member(s) are expected to provide neighboring residents an estimated timeline for construction, and advance notice of excessive construction-related noise that may occur.
- 1.3 **CODES AND REGULATIONS:** All work shall comply with applicable local, state, and federal requirements including but not limited to the current edition of the Uniform Building Code.
- 1.4 **WORK HOURS:** Contractors working for residents at individual manors and in carports are permitted to work from 9:00 AM – 5:00 PM Monday through Friday. No work whatsoever shall be permitted on Saturday and Sunday, and construction is restricted to 6 months out of every 12 months of the year.
- 1.5 **PLANS:** The Member applying for a Mutual Consent for Manor Alteration(s) shall provide to the Manor Alterations Department a detailed plan(s) for approval indicating all work to be done, i.e., size, location, description and specifications.
- 1.6 **DUMPSITES:** The premises shall be kept free from accumulation of waste materials and/or rubbish caused by the construction work. Member and/or his contractor is responsible for removal of debris and excess material and must leave work areas "**BROOM CLEAN**" daily.
USE OF COMMUNITY DUMPSITES FOR CONSTRUCTION RELATED DUMPING IS NOT PERMITTED. Contractor's dumpsters,

if required, must have location approved by the Manor Alterations Department.

- 1.7 **CONTRACTOR:** Installation must be performed by a California licensed contractor of the appropriate trade.
- 1.8 **CONTRACTOR'S CONDUCT:** Member's contractor(s), their personnel, and sub-contractors shall refrain at all times from using profanity, abusive or loud language, and must wear shirts at all times. Radio, MP3, CD or cassette players are not permitted on the project site. Contractor personnel will, at all times, extend and exhibit a courteous demeanor to residents.

2.0 **DEFINITIONS**

- 2.1. **Pedestrian ramp** is a sloping accessible route intended for pedestrian traffic to and from a manor.
- 2.2. **Slope** is the relative steepness of the land between two points and is calculated as follows: Slope is the horizontal distance and elevation change between the two points. The difference in elevation is divided by the distance and the resulting fraction is multiplied by 100 to obtain the percentage of slope.
- 2.3. **Cross slope** is the slope that is perpendicular to the direction of travel.
- 2.4. **Level area** is a specified surface that does not have a slope in any direction exceeding ¼ inch (6.4 mm) in 1 foot (305 mm) from the horizontal (2.083 gradient).

3.0 **SPECIFICATIONS**

3.1. **Materials** Concrete and/or block with a minimum 3.5 inches pour; and heavy broom-swept finish on the surface.

3.2. **Exterior ramps**

- 3.2.1. **Width.** The clear width of ramps shall in no case be less than 36 inches. (914mm). Handrails, curbs, wheel guides and /or appurtenances shall not project into the required clear width of a ramp.
- 3.2.2. **Slope.** The maximum slope of ramps shall be no greater than 1 unit vertical in 12 units horizontal (8.33 percent slope). Transitions from ramps to walks, gutters or streets shall be flush and free of abrupt changes.

- 3.2.3. **Changes in level not exceeding ½ inch.** Abrupt changes in level along any ramp shall not exceed ½ inch (12.7mm). When changes in level do occur they shall be beveled with a slope no greater than 1 unit vertical in 2 unit horizontal (50 percent slope). Changes in level not exceeding ¼ inch (6.35 mm) may be vertical.
- 3.2.4. **Changes in level exceeding ½ inch (12.7 mm)** shall be by means of a sloped surface not greater than 1 unit vertical in 20 units horizontal (5 percent slope).
- 3.2.5. **Cross slope.** The cross slope of ramp surfaces shall be no greater than ¼ inch (6.35 mm) per foot (2.083-percent slope).
- 3.2.6. **Ramps,** ramp landings and their approaches shall be designed so that water will not accumulate on the walking surface.

3.3. Exterior landings

- 3.3.1. **Level.** Ramp landings shall be level as defined.
- 3.3.2. **Height relative to door.** The top landing shall not be more than ½ inch (12.7 mm) lower than the top of the threshold of the doorway. (*See Figure 1*).
- 3.3.3. **Location of landings.** Landings shall be provided at the top and bottom of each ramp. Intermediate landings shall be provided at intervals not exceeding 30 inches (762 mm) of vertical rise. Landings are not considered in determining the maximum horizontal distance of each ramp.
- 3.3.4. **Size of top landings.** Top landings shall not be less than 60 inches (1524 mm) wide. Top landings shall have a minimum length of not less than 60 inches (1524 mm) in the direction of the ramp run (5 feet x 5 feet). (*See Figure 2*).
- 3.3.5. **Size of intermediate landings.** The width of intermediate landings shall not be less than the clear width of the ramp, and shall not be less than 60 inches (1524 mm) in length (*See Figure 2*).
- 3.3.6. **Size of intermediate turning landings.** The width of intermediate turning landings shall not be less than the clear width of the ramp, and shall not be less than 60 inches (1524 mm) in length (*See Figure 2*).
- 3.3.7. **Size of bottom landings.** The width of bottom landings shall not be less than the clear width of the ramp, and shall not be less than 60 inches (1524 mm) in length (*See Figure 2*).
- 3.3.8. **Encroachment of doors.** Doors in any position shall not reduce the minimum dimension of the landing to less than 42 inches (1067 mm) and shall not reduce the required width by more than 3 inches (76.2 mm) when fully open. That is, the length of the landing shall equal or exceed the width of the door plus 42 inches (*See Figure 3*).

3.4. Maneuvering clearances at doors.

- 3.4.1. **General.** Landings at exit doors shall have a length in the direction of the door swing of at least 60 inches (1524 mm) and a length opposite

- the direction of the door swing of at least 44 inches (1118 mm) measured at right angles to the plane of the door in its closed position.
- 3.4.2. Strike edge maneuvering space.** The width of the level area on the side to which the door swings shall extend at least 24 inches (610 mm) past the strike edge of the door. **Note:** 24 inches (610 mm) is preferred.
- 3.4.3. Front approach.** The following provisions shall apply to swinging doors with front approach:
- 3.4.3.1. Pull side** For pull side approach the landing shall extend in the direction of the door swing at least 60 inches (1524 mm). (See *Figure 4*).
- 3.4.3.2. Push side** For push side approach, the landing shall extend in the direction of the door swing at least 60 inches (1524 mm). (See *Figure 4*).
- 3.4.3.3. Push side with closer and latch** Doors with push side approach having both a closer and a latch shall be provided with a clear and level area extending a minimum of 12 inches (305 mm) past the strike edge on the approach side of the door. (See *Figure 4*).
- 3.4.4. Hinge side approach.** The following provisions shall apply to swinging doors with hinge side approach:
- 3.4.4.1. Pull side** Doors with pull side approach shall be provided with a level landing not less than 60 inches (1524 mm) in depth. A clear and level area shall extend a minimum of 36 inches (914 mm) past the strike edge on the approach side of the door. (See *Figure 5*). Exception. Doors with pull side approach and a level landing greater than 60 inches (1524 mm) in depth shall be provided with a clear and level area at least 24 inches (610 mm) past the strike edge of the door.
- 3.4.4.2. Push side** Doors with push side approach shall have a level landing not less than 44 inches (1118 mm) in depth, and shall be provided with a clear and level area extending a minimum of 54 inches (1372 mm) from the strike edge of the door jamb past the hinge side of the door. Doors with a latch and closer shall have a level landing not less than 48 inches (1219 mm) depth at the push side of the door. (See *Figure 5*).
- 3.4.5. Latch side approach.** The following provisions shall apply to swinging doors with latch side approach:
- 3.4.5.1. Pull side** Doors with pull side approach shall have a level landing not less than 60 inches (1524 mm) in depth, and shall be provided with a clear and level area extending a minimum of 24 inches (610 mm) past the strike edge on the approach side of the door. (See *Figure 6*).
- 3.4.5.2. Push side** Doors with push side approach shall have a level floor or landing not less than 44 inches (1118 mm) in depth, and shall be provided with a clear and level area extending a minimum of 24 inches (610 mm) past the strike edge on the approach side of the door. Doors with a closer shall have a

level floor or landing not less than 48 inches (1219 mm) depth at the push side of the door. (See Figure 6).

3.5. Handrails

- 3.5.1. **Ramp height.** Ramps more than 30 inches (762 mm) above the adjacent floor or ground and open on one or both sides shall be provided with handrails.
- 3.5.2. **Where required.** Handrails shall be provided at each side of ramps when the slope exceeds 1 unit vertical in 20 units vertical (5 % slope). Handrails on all ramps shall be continuous. **Exception:** Ramps that serve an individual dwelling unit may have one handrail, except that ramps open on one or both sides shall have handrails provided on the open side or sides.
- 3.5.3. **Handrail height.** The top of handrails shall be 34 to 38 inches (864 to 965 mm) above the ramp surface.
- 3.5.4. **Handrail ends.** Handrail ends shall be returned.
- 3.5.5. **Handrail extension.** Handrails shall extend a minimum of 12 inches (305 mm) beyond the top and bottom of the ramp. Where the extension creates a hazard, the termination of the extension shall be rounded or returned smoothly to the floor, wall or post. (See Figure 7).
- 3.5.6. **Handrail projections.** Handrails projecting from a wall shall have a space of 1-1/2 inches (38.1 mm) between the wall and the handrail. Handrails shall not reduce the required minimum clear width of the ramps. Handrails may be located in a recess if the recess is a maximum of 3 inches (76.2 mm) deep and extends at least 18 inches (457 mm) above the top of the rail. Any wall or other surface adjacent to the handrail shall be free of sharp or abrasive elements.
- 3.5.7. **Handrail grips.** The handgrip portion of handrails shall not be less than 1¼ inches (31.75 mm) nor more than 2 inches (50.8 mm) in cross-sectional dimension or the shape shall provide an equivalent gripping surface. The handgrip portion of handrails shall have a minimum radius of 1/8 inch (3.17 mm). Handrails shall not rotate within their fittings. (See Figure 8).

3.6. Curbs and wheel guides.

- 3.6.1. **Application** Ramps exceeding 10 feet (3048 mm) in length and ramp landings having a vertical drop exceeding 4 inches (101.6 mm), shall be provided with one of the following:
- 3.6.2. **Specifications** Guide curbs a minimum of 2 inches (50.8 mm), in height at each side; or wheel guide rails at each side, centered 2 to 4 inches (50.8 to 101.6 mm) above the surface of the ramp, or ramp landing. (See Figure 7).
- 3.6.3. **Exception:** Ramps or ramp landings bounded by a wall or fence.

3.7. Hazards on accessible routes

- 3.7.1. **Headroom clearance.** Ramps that are a part of a dwelling's primary egress system shall have a minimum clear headroom of 84 inches (2134 mm).
- 3.7.2. **Exception:** Doorways and archways less than 24 inches (610mm) in depth may have a minimum clear headroom of 80 inches (2032 mm).
- 3.7.3. **Overhanging obstructions.** Any obstruction that overhangs a ramp shall be a minimum of 84 inches (2032 mm) above the walking surface as measured from the bottom of the obstruction. (See *Figure 9*).

3.8. Figures

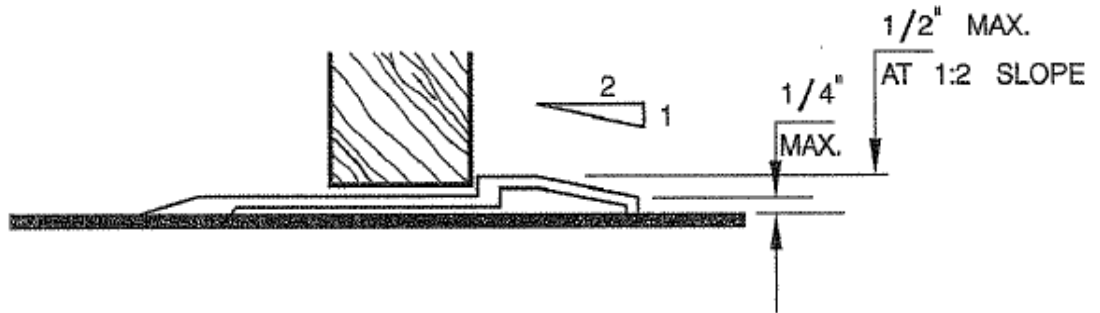

THESE DIAGRAMS ILLUSTRATE THE SPECIFIC REQUIREMENTS OF THESE REGULATIONS AND ARE INTENDED ONLY AS AN AID FOR BUILDING DESIGN AND CONSTRUCTION.

Figure 1

Thresholds

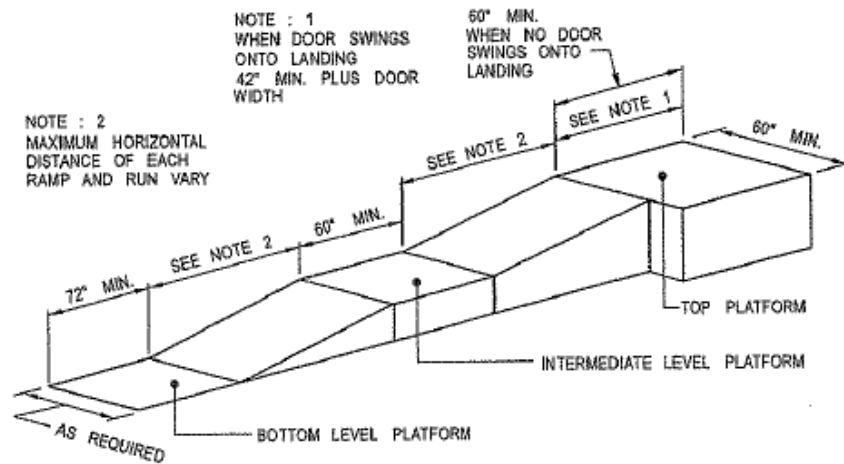

(a) STRAIGHT RAMP RUN

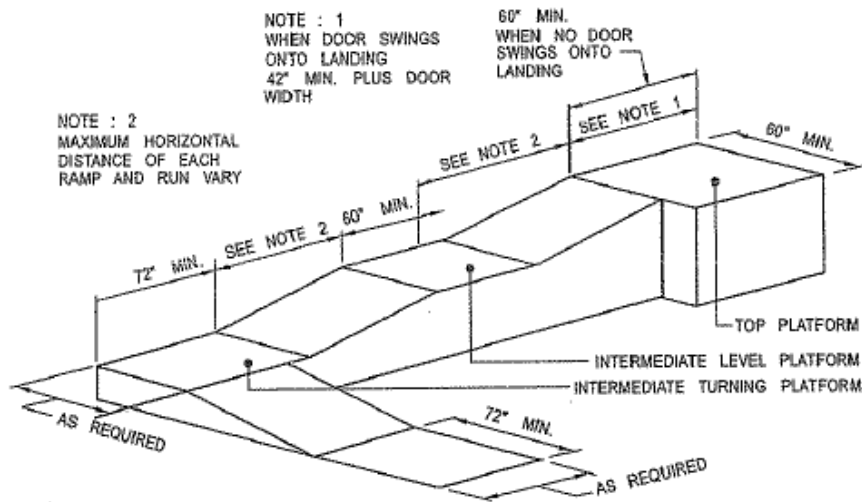

(b) RAMP WITH TURNING PLATFORM

THESE DIAGRAMS ILLUSTRATE THE SPECIFIC REQUIREMENTS OF THESE REGULATIONS AND ARE INTENDED ONLY AS AN AID FOR BUILDING DESIGN AND CONSTRUCTION.

Figure 2

Ramp Dimensions

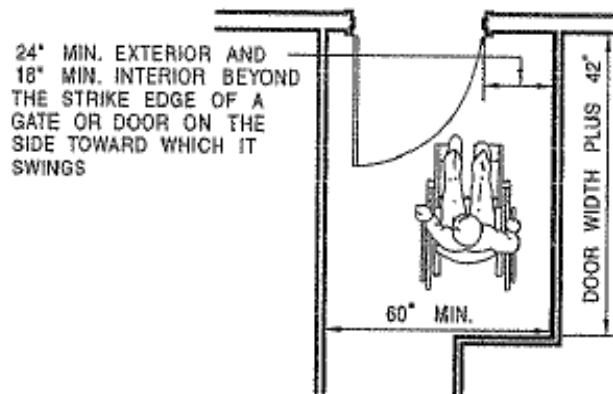

(b) RAMP LANDING AT DOORWAY

THESE DIAGRAMS ILLUSTRATE THE SPECIFIC REQUIREMENTS OF THESE REGULATIONS AND ARE INTENDED ONLY AS AN AID FOR BUILDING DESIGN AND CONSTRUCTION.

Figure 3

Ramp Landing and Doorway

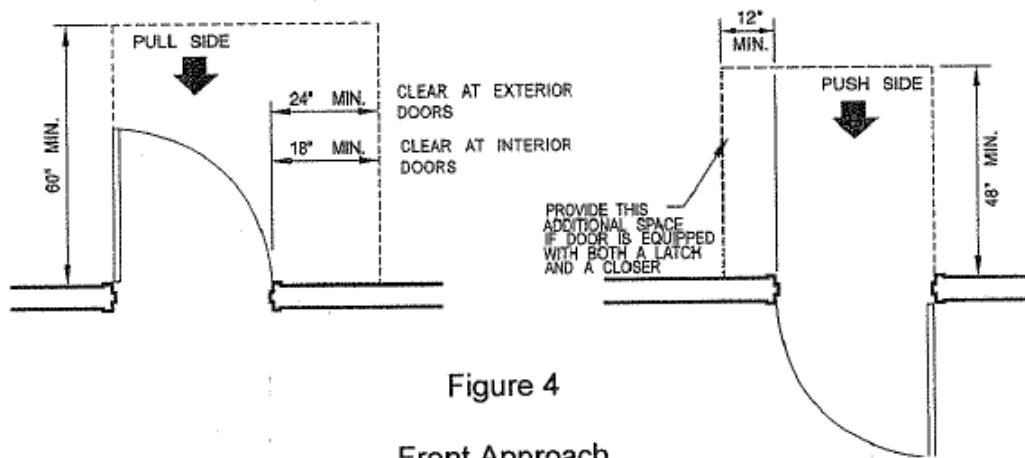

Figure 4

Front Approach Swinging Doors

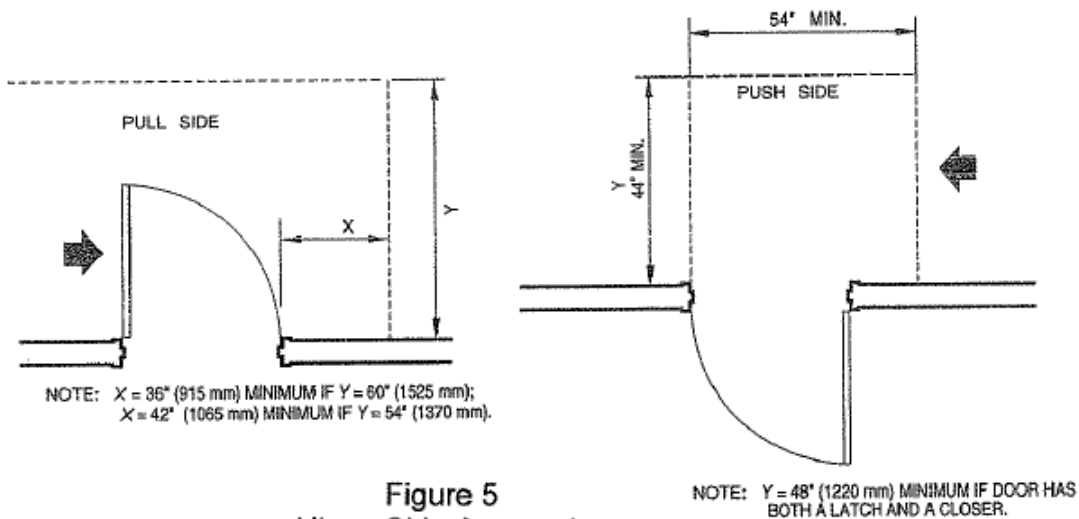

Figure 5
Hinge Side Approach Swinging Doors

THESE DIAGRAMS ILLUSTRATE THE SPECIFIC REQUIREMENTS OF THESE REGULATIONS AND ARE INTENDED ONLY AS AN AID FOR BUILDING DESIGN AND CONSTRUCTION.

LEVEL MANEUVERING CLEARANCE AT DOORS

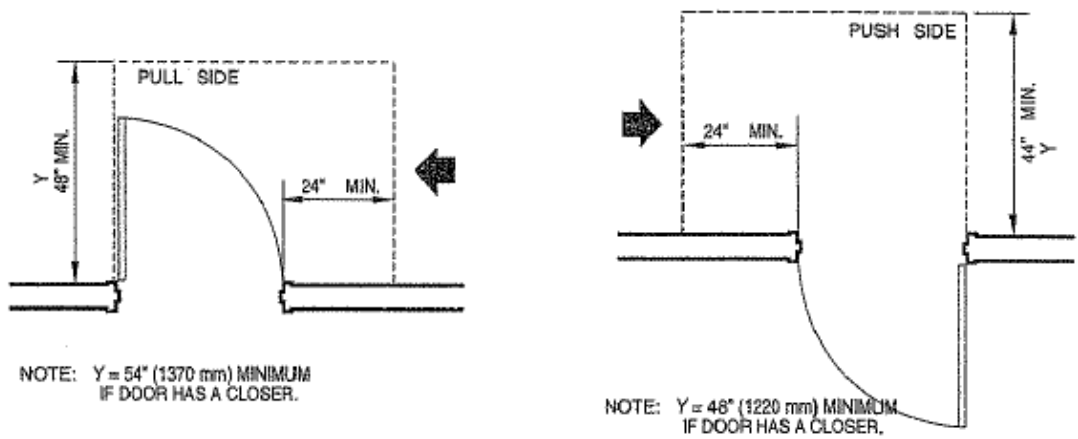
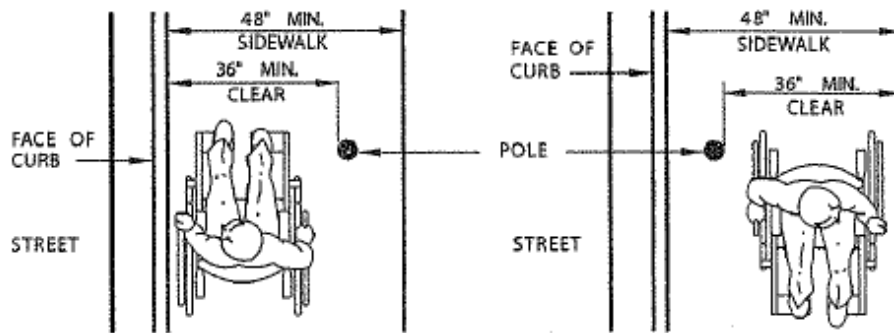
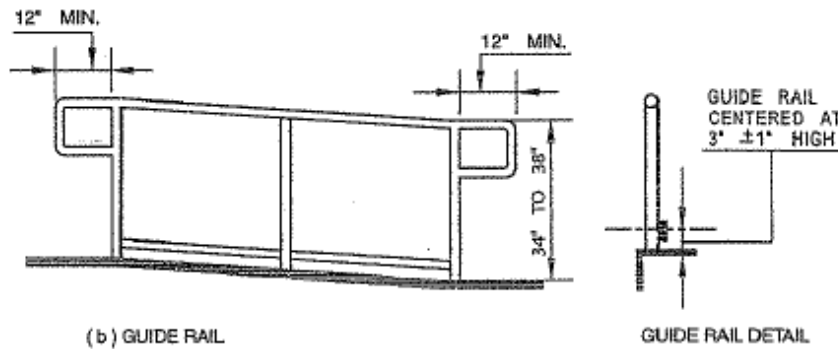

Figure 6
Latch Side Approach
Swinging Doors



(a) SIDEWALK OBSTRUCTIONS



(b) GUIDE RAIL

GUIDE RAIL DETAIL

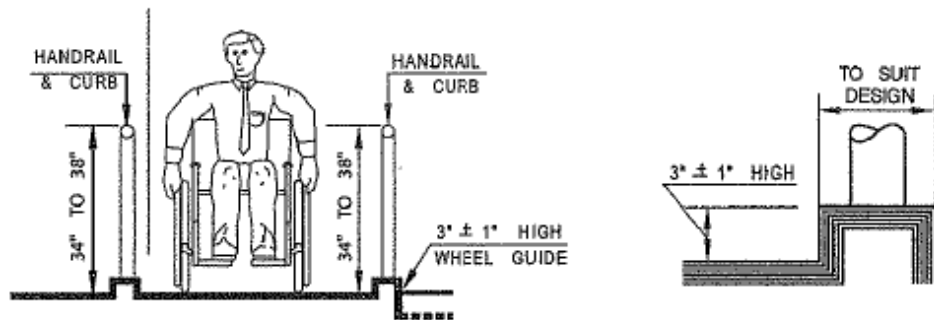

(c) WHEEL GUIDE

WHEEL GUIDE DETAIL

THESE DIAGRAMS ILLUSTRATE THE SPECIFIC REQUIREMENTS OF THESE REGULATIONS AND ARE INTENDED ONLY AS AN AID FOR BUILDING DESIGN AND CONSTRUCTION.

Figure 7

Ramps and Sidewalks

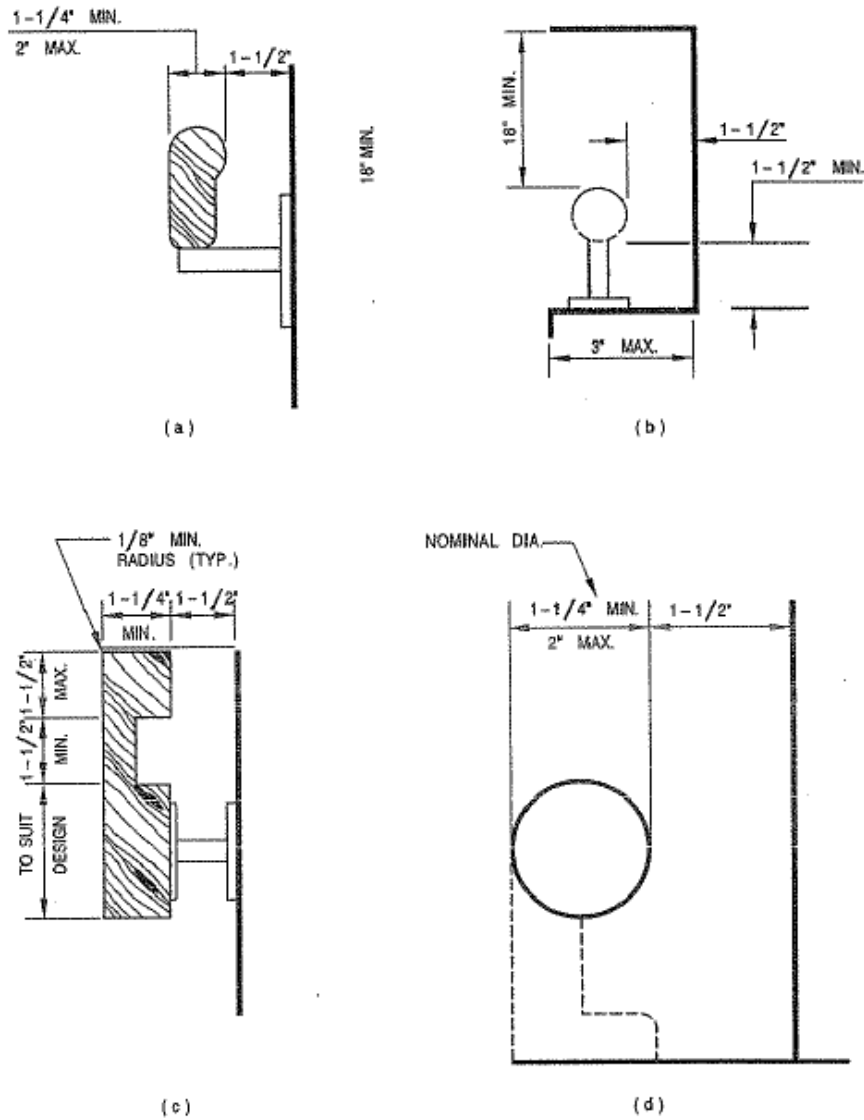

THESE DIAGRAMS ILLUSTRATE THE SPECIFIC REQUIREMENTS OF THESE REGULATIONS AND ARE INTENDED ONLY AS AN AID FOR BUILDING DESIGN AND CONSTRUCTION.

Figure 8

Handrails

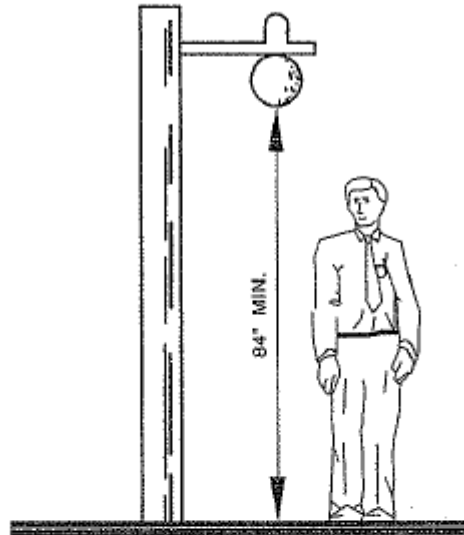

THIS DIAGRAM ILLUSTRATES THE SPECIFIC REQUIREMENTS OF THESE REGULATIONS AND IS INTENDED ONLY AS AN AID FOR BUILDING DESIGN AND CONSTRUCTION.

Figure 9

Overhanging Obstruction