

**ALUMINUM & LATTICE COVER NOTES**

**Light and Ventilation** h h ght pat wal must  
 pr v d h t he ope rea h ng r wal n  
 d l wall equ l t t % (percent) h  
 r be w n mun ur by h urr nt d ( su h  
 h l r) ur by h urr nt d ( su h  
 Ua f r m g Cod wh r wa can n t be ow (F  
 xa l Atr um) h c ve ly v t h rea  
 v h t ft u cover un b tructed

**Area to be Covered** C v r w l ly over h p t  
 d n by h pat lab wal nd cat h  
 tandar l

**Overhangs** v zhan n n w be hown h  
 dr w r det ra nd by he M era nd  
 pect p r tment

**Lattice Size** Latt y be x x r x  
 t pt l p ng (M n mun " n n t be  
 l t

**Paint Color** ll w od pa t at n match h  
 x t ng woo r m r

**Corbels** C r bel pt n prov d hey w od  
 not xc v ly rg detera by M era  
 nsp ct Departa nt

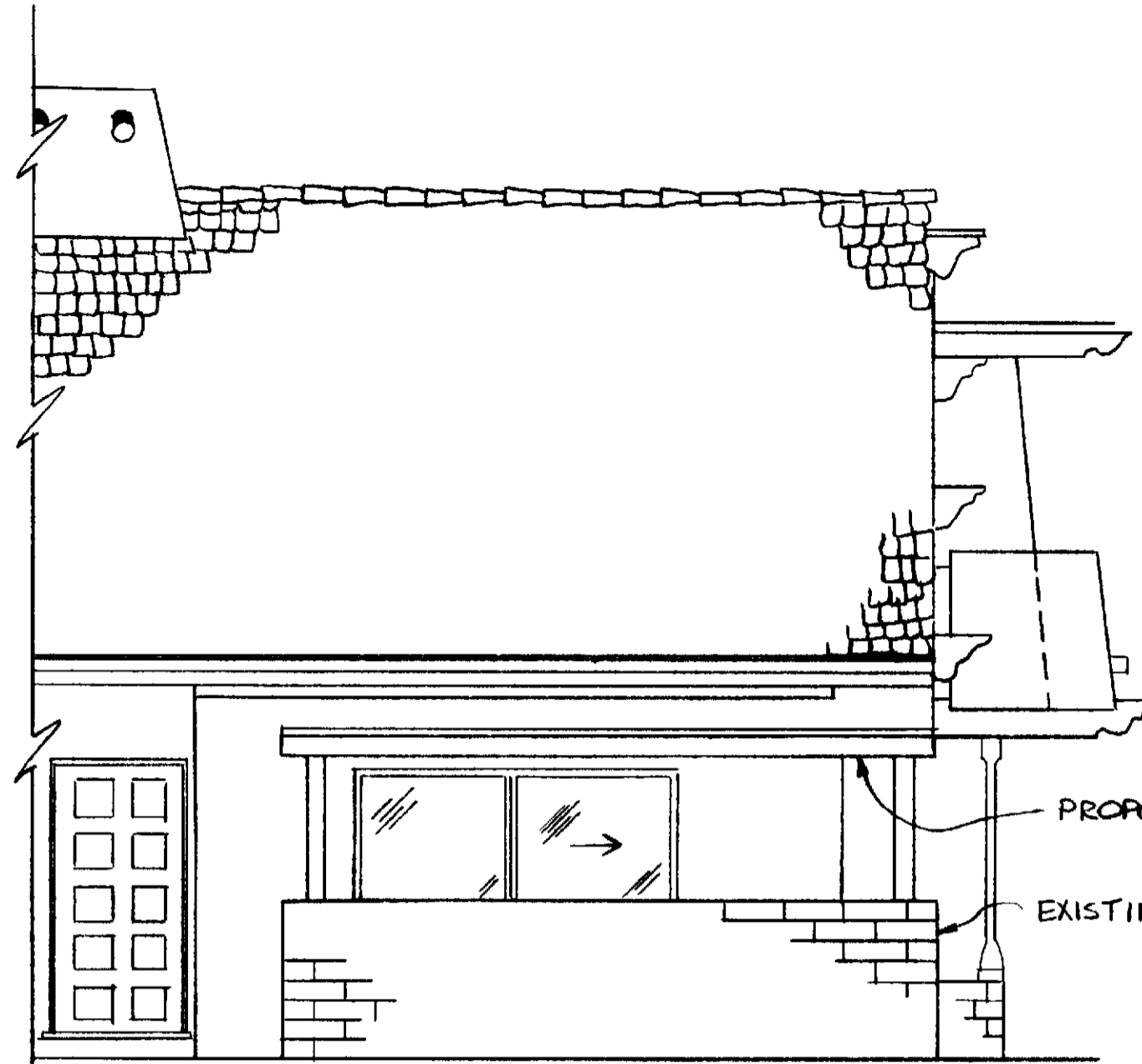

**FRONT ELEVATION**  
 SCALE 1/4"=1'-0"

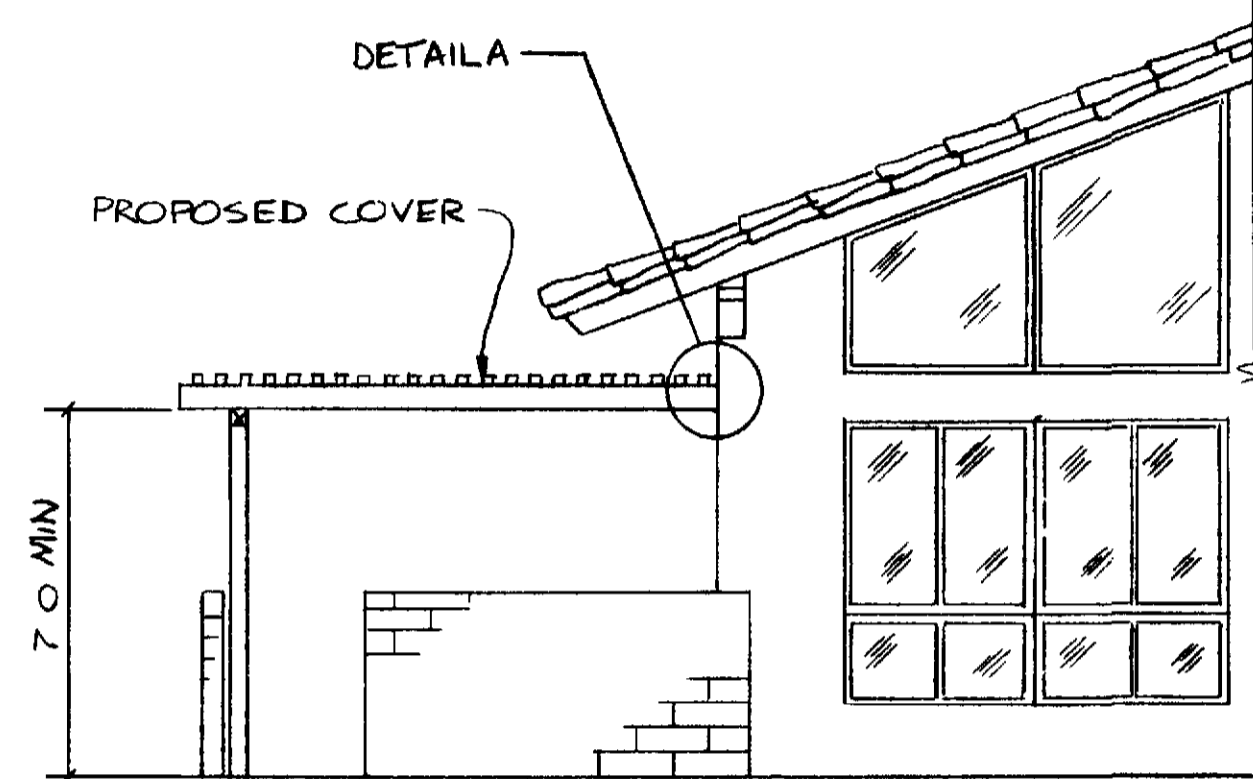

**SIDE ELEVATION**  
 SCALE 1/4"=1'-0"

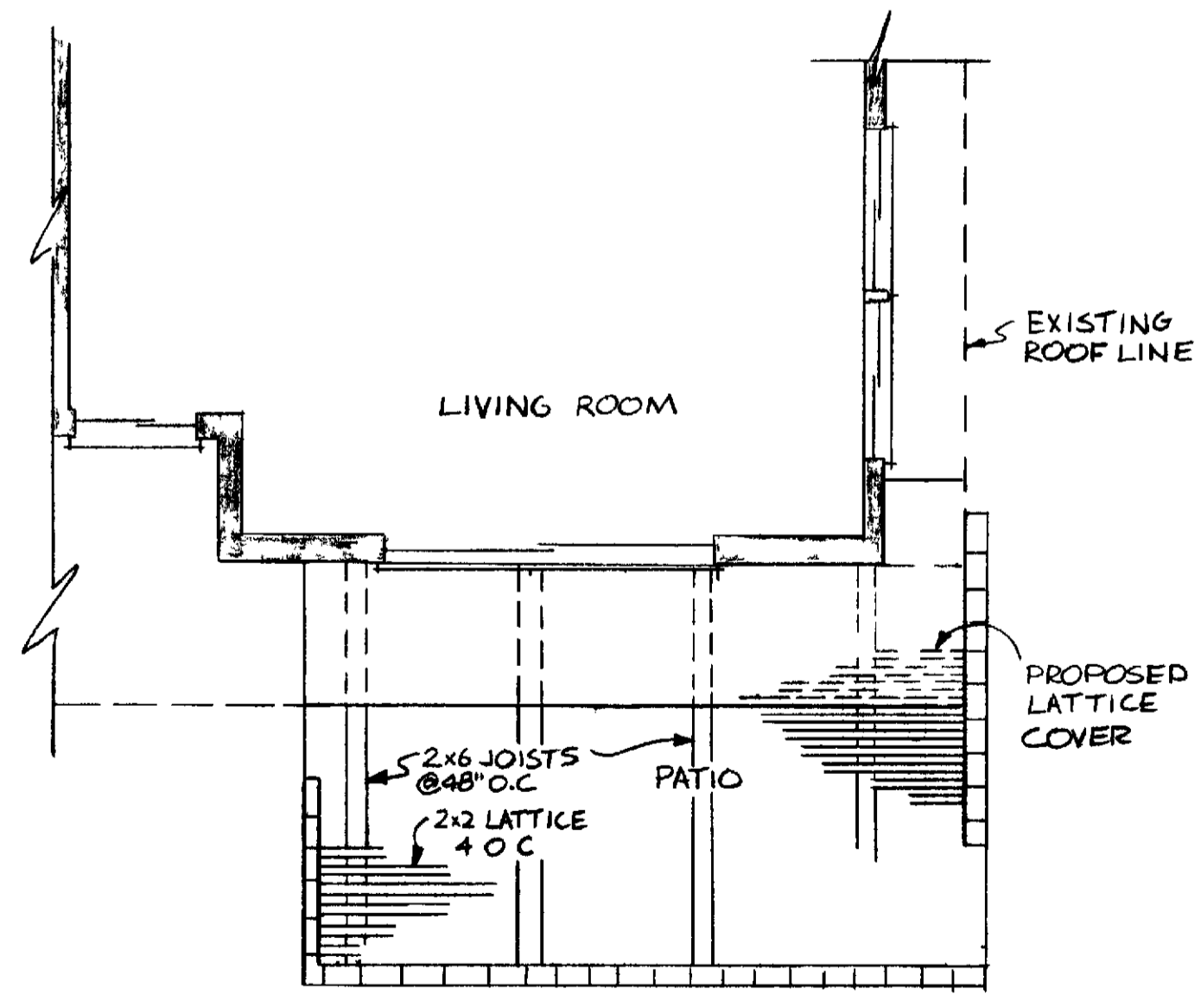

**FLOOR PLAN**  
 SCALE 1/4"=1'-0"

**Lattice Posts** x s post r ceptable  
 x l b inside pat wal Post y be o wal ly  
 uch wal has bea construct pected f such  
 bea ng od

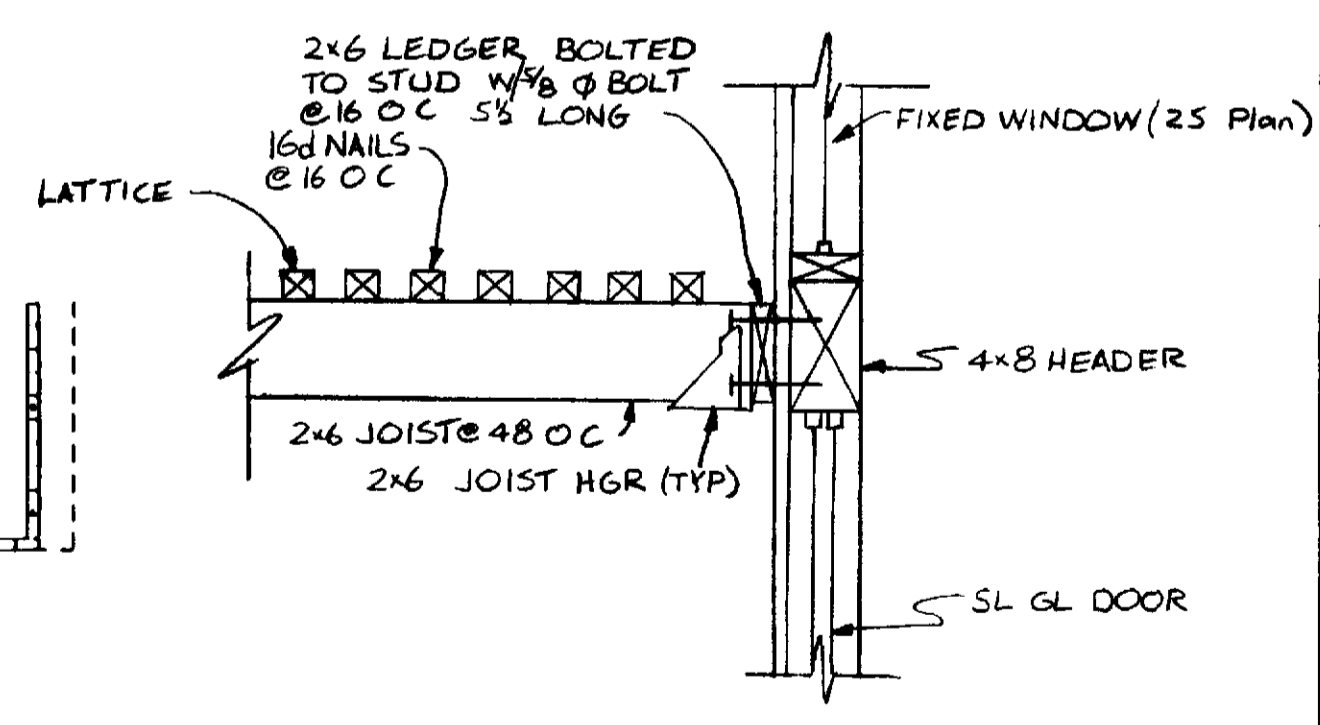
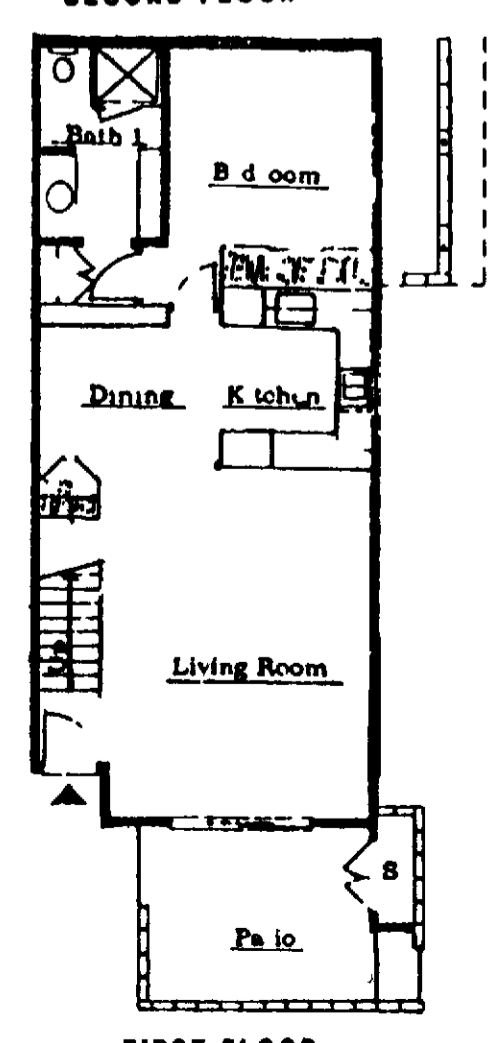
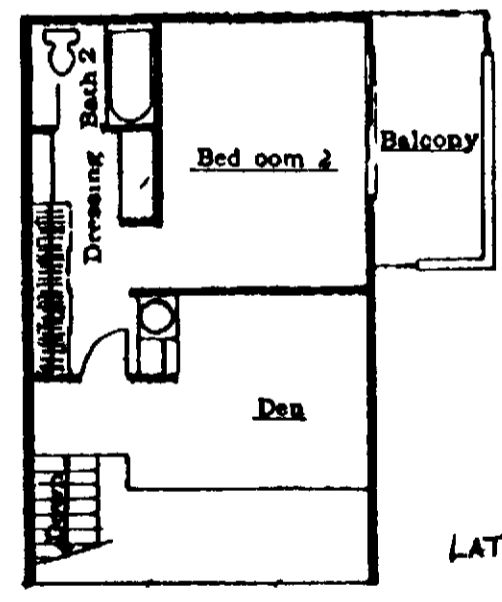

**DETAIL A**  
 SCALE 1'-1'-0"

**GENERAL NOTES**

h dr wing nd pe ificati n nd copi th r f  
 r g l instruments f r vic f r us the own r

Prof i nal Coma unity Man gement  
 P Box  
 Laguna Hill CA 6  
 (Hereaft r known P M )

Agent f r Laisur W rld Laguna Hill Califera nd  
 uth ri d repr sentativ the de ignated property  
 Only nd remai th sol property f the designer  
 Unauthori ed us i prohibited

**County Street Address:**  
 \_\_\_\_\_  
 \_\_\_\_\_

**Tract No. \_\_\_\_\_ Lot No. \_\_\_\_\_**

3 **Insurance:** Certal insurance ( ) r required  
 outlined by the P M Permit nd inspections  
 D partment Should they request uch in urance the  
 polici must be take ut i own r name

**Guarantee, Warranties, etc:** Th work f ch tr d  
 hall be gu rant ed by c ntr ctor

**Cutting, Patching, etc:** Each trade shall at ll  
 tim do th ir own cutting patching fitting tc To  
 ak sveral part come togeth r properly fit nd t  
 re iv r to be r ceived by th work f other trad

**Clean-Up:** All trad h ll t ll time keep th  
 premis fr from oculation f wa t mat rill r  
 rubbish caused by th ir work Contr ct r i responibl  
 for remov l f debri nd exc material and must  
 leave work r "broom l " both daily nd upon  
 compl tio f work U f community dmpst i not  
 permitted

6 **Code:** All work sh ll comply with the curr nt dition  
 f the Unif ra Building Cod tat nd local ode

9 **General Notes:** Each trad shall be h ld responsibl  
 for knowl dge f general not list d her i r  
 l ewh r within the dr wing

**Fees:** All permit nd pl heck f shall be taken  
 out nd paid for by the r id nt nd/ r hi ntractor

**Interpretation:** t i imper tive that th tractor  
 v rify ll dim ns ns nd ondit ns shown o  
 the drawing at the j b it pri r t commencing  
 n tructi nd inf ra th P M Permit nd  
 n p tien Department of ny discrepancies eo fil ts  
 r omi n bef r beginning/proc edi g with th work

**Dimensions:** Dime n h ve pr d no over cal

**Manufacturer's Directions:** Wher manufactur r  
 directi ns/specific tions ar called f r they sh ll be  
 consid r d part f the drawings

**Construction Regulations:** The drawing nd work  
 perf rmed shall t all time be governed by the  
 ppli bl pr vi n f f deral tat nd local  
 l w

**Facilities:** Temporary toil t shall be provided per  
 l cal uthoriti

**Barricades:** C tructi n barricad if required  
 hall oaf ra t the requirement f local uthorities  
 F r saf ty th publi hall be prot cted nd/ r  
 shi lded from the construction work/ it at all times  
 during the c tract

**Structural:** Th tractor i de igne stabl unit  
 ft r ll component parts are in plac Therefore  
 contractor hall provide ll horing nd bracing  
 r quired t in ur th tabilit y nd/er all parts  
 during constructi

**Standards:** All work h ll be performed t the best  
 tandar practice f the trade ( ) All contract r  
 damaged wrk hall be r pl ced t th c ntr ctor  
 xpens

**Construction Materials:** All materials shall be of  
 t ndard grade r better ul otherwis n ted

**Discrepancies:** Any discr pancies betw pl n  
 building nd local od requirements that may ffect  
 th in t latio fabric ti n r over ll work i any  
 way shall be immedi t ly brought t th ttention f  
 P M Permit nd nspecti Department by the  
 c ntractor

**Work Hours:** N work hall commnc pri r t 7  
 m and n work will be permitted ft r 8 00 p m Monday  
 through Frid y Saturday work should be held t  
 inimum nd n work what ever Sunday

PATIO COVER LATTICE	<b>26</b>
JJ04	
DRAWN CHRIS MANGELS	
APPROVED TERRY WHITE	
DATE (3/29/68) 7/23/93	
 F U E — U N I L L Y E N T A N — N D M M	